



United States Systems, Inc.

Pneumatic Conveying - Bulk Bagging - Industrial Automation

YOUR PARTNER IN PROCESS SUCCESS

CONCEPT
DESIGN
ENGINEERING
FABRICATION
COMMISSIONING



"The most versatile bagger on the market"

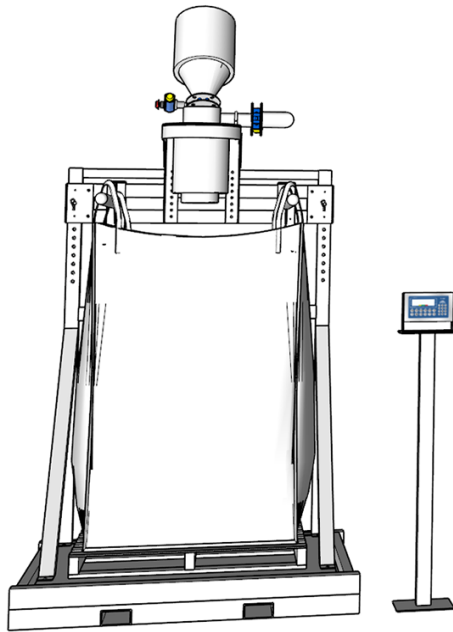

Base Model with Filter and Scale

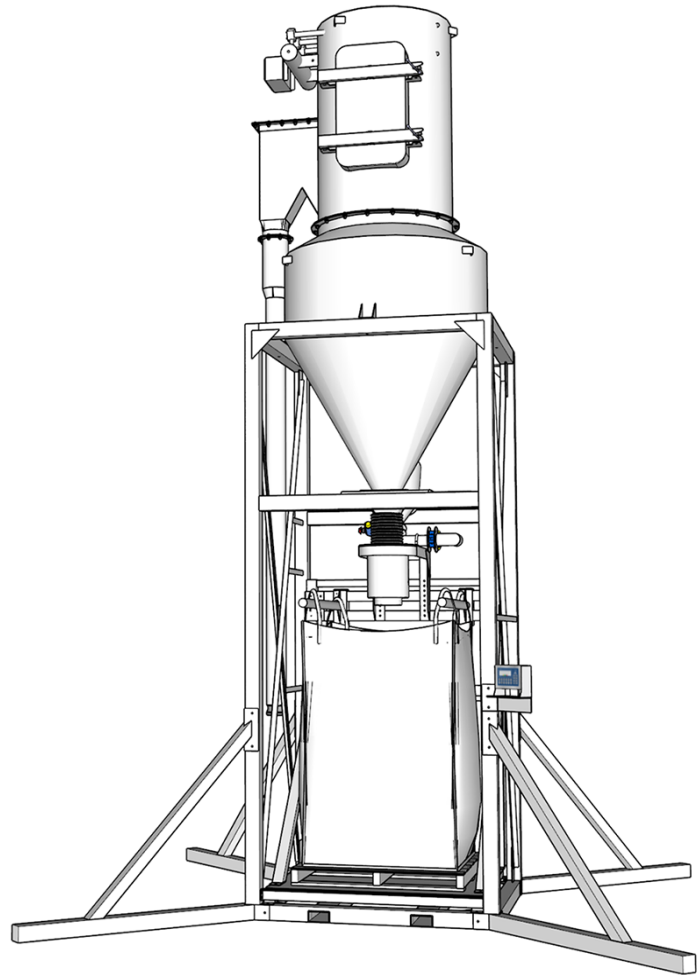

Base Model With Integrated Pulse-Jet Filter Hopper

FEATURES AND OPTIONS:

- Accommodates up to 67" FIBC Bulk Bag wall height
- Width-adjustable bag loop guides with rounded ends
- Food-grade flexible product sleeve for vertical adjustment
- Forklift tine-slots for portability
- Stainless steel product spout with inflatable cuff
- Easy-reach hand-actuated air valve for inflatable cuff
- Floor scale load cells
- Integrated weight indicator
- Slide-gate valve with dribble function
- Flared legs for stability
- 60 degree slope for easy product flow
- Vibrator mounts for product flow
- Filtered Surge Bin with pulse-jet technology
- Easy access door with toolless entry
- Bag inflation fan for quick filling
- Stainless steel food-grade product contact areas
- Bag filling dust filter for dusty or hazardous materials
- Motorized height adjust
- Densification

BENEFITS:

- Use a wide-variety of bulk bags
- Pairs well with a USS SKIDPOT™ Pneumatic Conveyor
- Durable design for decades of use
- Dribble function for accurate weighing
- Product flows easily
- Safe for operators to use
- Long-lasting industrial-duty components
- Can be used at one location or different sites
- Capital investment moves where you need it most
- Densification option optimizes bag utilization
- Motorized height adjust makes changing bag size a breeze
- Easy removal of filtration media
- Easy to ship
- Easy to use
- Easy to move
- Easy to clean
- Easy to maintain